



USTL-230/734 INSTALLATION MANUAL

REV: C (6/25/2021)



© Kleinn Air Horns 2021, All Rights Reserved

PO Box 91278 Tucson, AZ 85752

Phone: (520) 579-1531

Web: <https://www.kleinn.com>



This digital PDF is interactive

Please save ink and paper...



Open interactive manual using Adobe Reader[®]

on PC, Mac, and smart devices



Table of Contents

1	How to Use This Manual	6
1.1	Interactive Manual Using Adobe Reader	6
1.2	Your SKU Number & this Manual.....	6
1.2.1	USTL-230 or USTL-734	6
1.3	Illustration/Photo Details & Orientation	6
2	Safety First	7
3	Application Chart	8
3.1	Bolt-On Vehicle List.....	8
3.1.1	Full-Size Trucks by Generation.....	8
3.1.2	Mid-Size Trucks by Generation	9
3.2	Known Fitment Issues	10
3.2.1	Newer RAM Trucks.....	10
3.3	Excluded Vehicles.....	11
3.4	Aftermarket Product Compatibility	11
4	Installation Overview	12
4.1	Kit Layout & System Location(s)	12
4.2	Install Process Outline.....	13
4.3	Approximate Installation Time.....	13
5	List of Tools & Supplies	14
5.1	Standard Tool List (Required)	14
5.2	Special Tool List (Recommended).....	14
5.3	Shop Consumables List (Recommended).....	14
6	Parts List.....	15
6.1	Review Parts List	15
6.2	Pre-Packaged Electromechanical Kit Items.....	15
6.3	Air Fittings & Related Items	16
6.4	Electrical Components & Related Items	17
6.5	Mounting Brackets & Special Hardware	17
6.6	Hardware, Fasteners, & Soft Parts.....	18
7	Test Fit USTL*	19



8 Bench Assembly 20

8.1 Assemble Air Fittings to Air Tank 20

8.2 Assemble Air Filter to Air Compressor 21

8.3 Attach Threaded Rod to USTL Structure 21

8.4 Assemble Kit Components to USTL Structure 22

8.4.1 Assemble Air Horns to USTL Structure 22

8.4.2 Assemble Compressor to USTL Structure 22

8.4.3 Assemble Tank to USTL Structure 23

8.4.4 Adhere Rubber to USTL Structure 23

8.4.5 Install Snap-In Caps 24

8.4.6 Attach Leader Hose to Tank & Route Air to Horns 24

9 On-Vehicle Mechanical Assembly 26

9.1 Remove Spare Tire 26

10 On-Vehicle Electrical Installation 27

10.1 Relay & Fuse Diagram for Air Horn System 27

10.2 Disconnect Vehicle Battery(s) 28

10.3 Connect Wires to Fuse & Relay 28

10.4 Install Horn Button 29

10.5 Connect Pressure Switch 29

10.6 Connect Air Compressor 29

10.7 Connect Air Horn Solenoid(s) 29

10.8 Raise USTL Assembly into Final Position 30

10.9 Secure Wiring to Vehicle 30

11 Final Steps & Testing 31

11.1 Reconnect Vehicle Battery(s) 31

11.2 Test Air Compressor 31

11.3 Test Train Horns 31

11.4 Test Quick Connect Coupler 31

12 General Operation 32

12.1 Compressor Operation 32

12.2 Horn Operation 32



13	Routine Maintenance	32
14	Warranty Information	33

END OF TABLE OF CONTENTS



1 How to Use This Manual

1.1 Interactive Manual Using Adobe Reader

It is recommended to open this digital PDF using Adobe Reader® to take advantage of following key features:

- **Hyperlinks** ([blue underlined text](#)) allow access to additional content via internet; click/tap to activate. Hyperlinks also allow users to jump to specific spots in within the document.
 - Includes [Installation Figures](#) and “[Figure xx](#)”
- **Table of Contents** page allows easily navigating this manual; click/tap any section line to go to it
- **Bookmarks** allow quick navigation to any section; click/tap
- **Zoom IN** on pictures by pressing “CTRL and +” at same time on PC, or pinch in on smart devices
- **Zoom OUT** on pictures by pressing “CTRL and -” at same time on PC, or pinch out on smart devices

To Download & Install Adobe Reader®

On PC or Mac:

- Visit <https://get.adobe.com/reader/otherversions/>

On Android/iOS, and Windows devices:

- Visit <https://get.adobe.com/reader/otherversions/>
-

1.2 Your SKU Number & this Manual

This manual covers installation, testing, and operation of the following SKU part numbers

1.2.1 USTL-230 or USTL-734

NOTE: Illustrations and pictures contained herein may represent only one kit part number. Where critical differences exist between kits, (i.e., different parts, orientation, mounting points, etc.) additional text, or necessary graphics are provided to minimize confusion.

Parts list explicitly state kit differences with **(BOLD TEXT)** inside parenthesis, shown below part number

1.3 Illustration/Photo Details & Orientation

This manual may use digitally created illustrations and/or actual photos of example vehicle. These graphics may not include exact items found on your vehicle (i.e., electrical wiring, fuel lines, body panels, etc.). Illustrations typically will be missing details and are for clarity to show critical mounting locations and orientation on vehicle.



Throughout the manual, yellow arrows with text reading “FRONT” may be present over illustrations and pictures. These arrows specify direction toward the front of the vehicle and provide clarity as to how illustration is viewed.

END OF SECTION



2 Safety First

Read this manual thoroughly before starting installation of this kit. Verify that you have all of the parts listed, and that you clearly understand the installation procedure. Contact Kleinn technical support with any questions.

Installation of this kit requires **moderate mechanical aptitude**; seek professional help if you're not competent using hand tools in tight uncomfortable spaces and around possibly rusted and sharp vehicle parts.

Before starting, obtain proper tools required to perform installation correctly, adequate lighting, eye protection, hearing protection (for operating train horns), and hand protection to guard against sharp edges and metal burrs which may be present on kit parts and/or vehicle parts.

Throughout this manual the following words may be used; be aware of their meaning and application.

CAUTION: means damage could occur to vehicle or kit parts during or after installation.

WARNING: means injury could occur to you or others, including damage to vehicle or kit parts.

DANGER: means serious injury or death could occur to you or others during installation.

END OF SECTION



3.2 Known Fitment Issues

3.2.1 Newer RAM Trucks

Some newer RAM trucks have a U-shaped structure inside the spare tire's rim that requires horns to be mounted facing the side of the truck, unless this structure is removed (this piece is welded on). The USTL will fit over this structure without modification.



Figure 1: RAM Spare Tire Location (2016 2500 Shown)



Figure 2: RAM Spare Tire Location Fitment

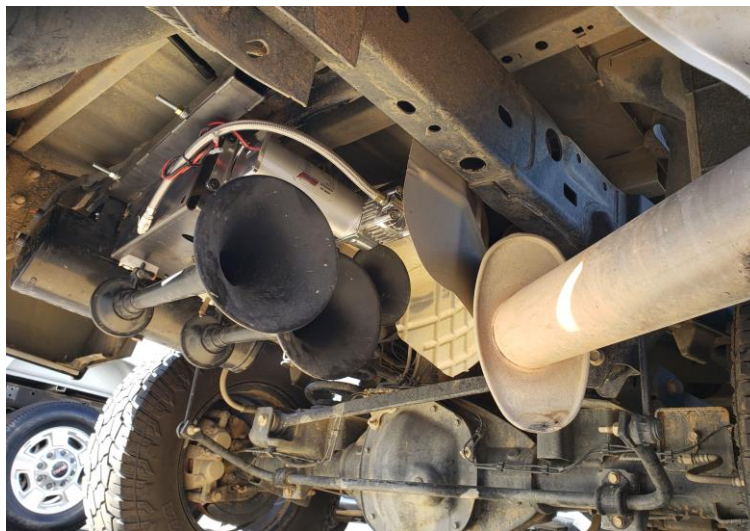

Figure 3: RAM Trumpets Passenger Side Installation



3.3 Excluded Vehicles

The following vehicles have been found to be **incompatible** with the designed kit:

MODEL YEAR	MODEL	DRIVE	ENGINE	BODY	TRIM
N/A	-	-	-	-	-

3.4 Aftermarket Product Compatibility

This kit has **not** been designed to work with the following aftermarket products:

- Aftermarket dual exhaust systems

NOTE: Review this manual in full before unpacking items to verify correct space and mounting locations exist with your aftermarket product(s). *To install this kit alongside your other aftermarket product(s), modification to the included parts, your vehicle, or your aftermarket product(s) may be required.*

END OF SECTION



4 Installation Overview

4.1 Kit Layout & System Location(s)

USTL-230/734 consists of the following components, located on vehicle as follows:

ITEM	DESCRIPTION	VEHICLE LOCATION	MOUNTING METHOD	APROX. INSTALL TIME
1	Air compressor	Spare Tire Location	Attach to structure. Winched into place.	2 hours
2	Tank			
3	Horns			





4.2 Install Process Outline

For person(s) with experience installing the USTL, a reminder of the install steps is provided below:

UNPACKAGE KIT (SECTION 7)

1. Layout and organize all parts

CONFIGURATION CHECK (SECTION 8)

2. Attach horns to USTL structure
3. Raise USTL into place to check for clearance

BENCH ASSEMBLY (SECTION 9)

4. Assemble horn kit components to USTL structure

ON-VEHICLE MECHANICAL ASSEMBLY (SECTION 10)

5. Lower spare tire

ON-VEHICLE ELECTRICAL ASSEMBLY (SECTION 11)

6. Install relay & fuse, route wiring, and install horn button
7. Connect all electrical items (air horn(s), pressure switch, air compressor)
8. Raise USTL assembly into place

FINAL STEPS (SECTION 12)

9. Test system

4.3 Approximate Installation Time

The USTL-230/734, is a multi-faceted product consisting of mechanical, electrical, and pneumatic components.

For a typical home mechanic, auto enthusiast, or technician installing this kit for first time; a professional installation job with setup and testing of final product, is estimated to take:

- **2 hours**

END OF SECTION



5 List of Tools & Supplies

5.1 Standard Tool List (Required)

1. Basic mechanic's 3/8" drive socket sets with extensions
 - Inch size sockets (5/16", 1/2", 9/16", 5/8", 3/4", 13/16", 7/8")
2. Basic mechanic's combination wrenches (box/open-end)
 - Inch size wrenches (5/16", 1/2", 9/16", 5/8", 3/4", 13/16", 7/8")
3. Basic mechanic's Allen wrenches
 - Inch size Allens (3/8")
4. Basic mechanic's screwdriver set (Philips, Flat Head)
5. Diagonal cutter/wire cutter pliers
6. Wire strippers
7. Wire terminal crimpers
8. Slip-joint pliers
9. Vise grips or locking pliers
10. Utility knife or utility razor blade

5.2 Special Tool List (Recommended)

1. 10-100 ft-lbs. torque wrench
2. Multi-meter for 12V DC electrical systems or equivalent
3. 12V DC test Light or equivalent

5.3 Shop Consumables List (Recommended)

1. Quality electrical tape
2. Di-electric grease for electrical connections
3. Heat shrink tubing for electrical connections
4. Medium-strength thread-locker (i.e., Blue Loctite® PN 242) or equivalent
5. Low-strength thread-locker (i.e., Purple Loctite® PN 222) or equivalent
6. Black/Clear silicone for drilling holes in body
7. Sandpaper or wire brushes for installing ground wires
8. Extra plastic zip ties > 6" long
9. Extra NPT sealant (i.e., Kleinn Air Horn Juice, Teflon tape, etc.)
10. Touch-up paint for frame/chassis/body (i.e., primer or black epoxy)
11. Typical cleanup supplies

END OF SECTION



6 Parts List

6.1 Review Parts List

Unpackage and organize kit across a large work area and verify all parts are included, as listed below. Contact Kleinn support with any questions.

1. Review pre-packaged kit items (K_)
2. Review Air Fittings and Tubing (F_)
3. Review Wiring and Accessories (E_)
4. Review Bolt-On Mounting Brackets (C_)
5. Review Hardware/Fasteners (H_)
6. Review Add-On Accessories (X_)
7. Familiarize yourself with how the parts assemble

6.2 Pre-Packaged Electromechanical Kit Items

NOTE: Items in this section come in their own packages and may include additional items inside package.

ITEM	QTY	PART NUMBER	DESCRIPTION	PICTURE
K1	1	6350RC (USTL-230 Only)	Air compressor kit, with included hardware, leader hose, remote air filter, connectors, and tubing.	
K2	1	6450RC (USTL-734 Only)	Air compressor kit, with included hardware, leader hose, remote air filter, connectors, and tubing.	
K3	1	The Beast 230 (USTL-230 Only)	230 Series Horn Kit, with included solenoid/valve, and 1/4" Air Tubing, 15 ft. long	
K4	1	The Demon 730 (USTL-730 Only)	730 Series Horn Kit, with included solenoid/valve, and 1/2" Air Tubing, 15 ft. long	
K5	1	6350RT	Air tank, 3 gallon, 7-port	





6.3 Air Fittings & Related Items

ITEM	QTY	PART NUMBER	DESCRIPTION	PICTURE
F1	1	50040*	Plug, 1/4NPT, External Hex	
F3	1	52175	Safety Valve, 175PSI, 1/4NPT	
F4	1	52835	Drain, 1/4NPT	
F5	2	51414NPTL	Adpt. 1/4NPT-1/4NPTF Elbow	
F6	1*	51214L (USTL-734 ONLY)	Comp. Fit. 1/4NPT-1/2 Elbow	
F7	1*	51414L (USTL-230 ONLY)	Comp. Fit. 1/4NPT-1/4 Elbow	
F8	1*	51414L (Included in 1302L)	Comp. Fit. 1/4NPT-1/4 Elbow	
F9	1	51214R	Reducer, 1/2NPT-1/4NPTF	
F10	1*	25012 (USTL-734 ONLY)	1/2" AIR TUBING	
F11	1	25014	1/4" AIR TUBING	



6.4 Electrical Components & Related Items

ITEM	QTY	PART NUMBER	DESCRIPTION	PICTURE
E1	1	2151	PRESSURE SWITCH, 1/4NPT	
E2	1	318-BK	Horn Button	
E3	1	340	RELAY, 12V, SPDT	

6.5 Mounting Brackets & Special Hardware

ITEM	QTY	PART NUMBER	DESCRIPTION	PICTURE
C1	1	USTL	STRUCTURE, SPARE TIRE MOUNT	



6.6 Hardware, Fasteners, & Soft Parts

ITEM	QTY	PART NUMBER	DESCRIPTION	PICTURE
H1	2		THREADED ROD, 3/8-16 X 16"	
H2	8		FLAT WASHER, 3/8"	
H3	4		LOCK WASHER, 3/8"	
H4	8		NUT, 3/8-16	
H5	6		FLAT WASHER, M8	
H6	6		NUT, M8-1.25	
H7	4		SOCKET-CAP SCREW, 7/16-14 x 1"	
H8	8		FLAT WASHER, 7/16"	
H9	4		LOCK WASHER, 7/16"	
H10	4		NUT, 7/16-14	
H11	2	USTL-RUBBER	RUBBER STRIP	
H12	4	USTL-CAP	SNAP-IN TUBE CAP	
H13	1		C-Channel Rubber	

END OF SECTION



7 Test Fit USTL*

*This step is optional, but is recommended if your vehicle is not listed as compatible on the [application chart](#).

1. Before continuing, temporarily attach the horns to the USTL structure using the supplied hardware, along with items [H5](#) and [H6](#), in the configuration shown.

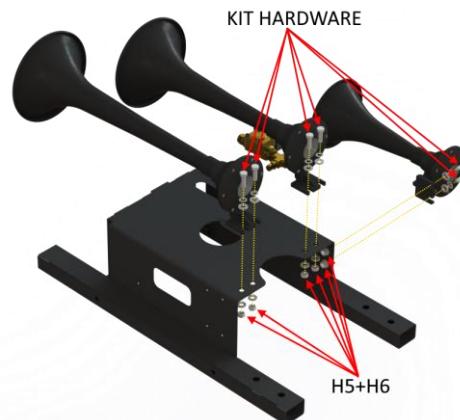

Figure 4: Default Horn Config. (734 horns shown)

2. Consult your owner's manual to lower and remove the spare tire. If the spare tire is not present, lower the winch.
3. Insert the winch flange through the 3-1/4" opening in the USTL structure.
4. Guide the USTL structure into place as it is raised.
5. Check for clearance with the default configuration. Note adjustments as needed. The structure may be mounted with horns facing front, rear, passenger's side, or driver's side of the vehicle. This installation guide will show horns facing the front of the vehicle.
6. Lower assembly
7. Optional: Remove horns.

END OF SECTION



8 Bench Assembly

Complete the following steps off of the vehicle to prepare for final installation.

When assembling components using bolts, nuts, washers, and lock washers follow the assembly order shown below:

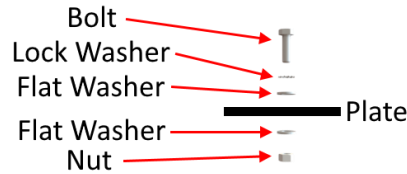

Figure 5: Hardware Assembly Order

It is recommended to use a thread locker and a torque wrench when tightening fasteners.

Use the following chart for torque specifications.

Item	Thread Size	Used for	Torque Spec (lb.-ft.)
H4	3/8-16	USTL structure threaded rods	23
H6	5/16-18	Horn mounting	13
H7	1/2-13	Tank mounting	57
-	10-32	Compressor mounting	2.5 (30 lb.-in.)

8.1 Assemble Air Fittings to Air Tank

1. Gather all necessary air fittings and the air tank. Ensure all threads on fittings and inside ports are clean.
2. Apply two small drops of [Kleinn Air Horn Juice](#) to each male pipe thread, before inserting.
3. Attach air fittings to the air tank, per below illustration. Use F1 if you do not wish to connect the remote air coupler.

[Click here to view fittings list](#)

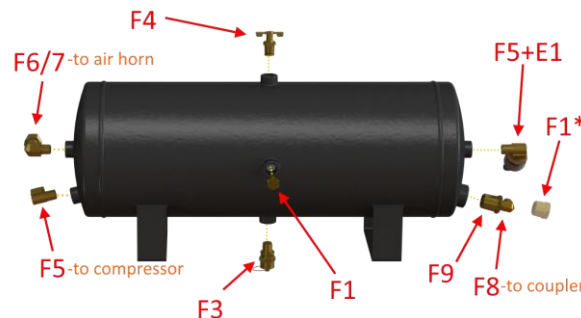

Figure 6: 6350RT with Fittings (734 shown)

4. Hand-tighten each fitting, then further tighten 1/4-1/2 turn using proper sized box-end wrench.



8.2 Assemble Air Filter to Air Compressor

1. Remove the compressor from its packaging, including hardware and air filter.
2. Review included directions in the compressor package pertaining to the remote air filter. Select the location on the vehicle where the air filter will be mounted, or if desired, filter housing may be secured to included structure using zip ties.
3. Pry-open the plastic air filter housing and ensure the foam filter is installed. Attach fittings for filter to the end of the air the compressor and filter housing. Follow instructions included in the compressor package.

NOTE: The air filter tubing is rigid and may be difficult to install over barb fittings. If necessary, use a hair dryer, candle, or heat gun at a safe distance to soften the end of the air tubing and place over fitting. Do not bend tubing excessively and cause it to kink. Use even heat if necessary, to bend tubing sharply.



Figure 7: Air Compressor Remote Air Filter and Tubing (shown without air compressor)

8.3 Attach Threaded Rod to USTL Structure

Repeat the following steps twice, once for each threaded rod (H1) provided.

1. Insert threaded rod halfway through USTL structure.
2. Add hardware in order shown.

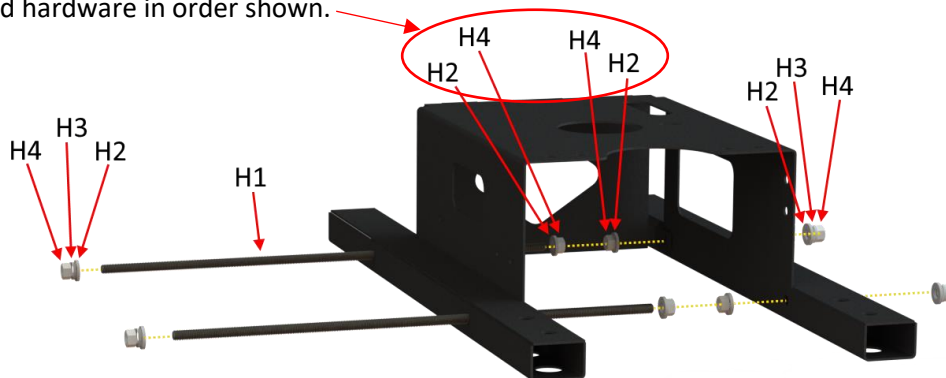

Figure 8: Threaded Rod Assembly

3. Insert threaded rod the rest of the way though USTL structure.
4. Add remaining hardware as shown.
5. Center threaded rod on the structure and tighten hardware.
6. Repeat for second threaded rod.



8.4 Assemble Kit Components to USTL Structure

8.4.1 Assemble Air Horns to USTL Structure

1. ****NOTE:** Trumpet may need to be removed from horn driver to install solenoids.
2. Use the hardware supplied with the air horn kit, along with items [H5](#) and [H6](#), to attach the horns to the USTL structure. (Supplied horn mounting bar is not used)
Swap horn location(s) and fitting(s) as needed. See [Section 8](#).

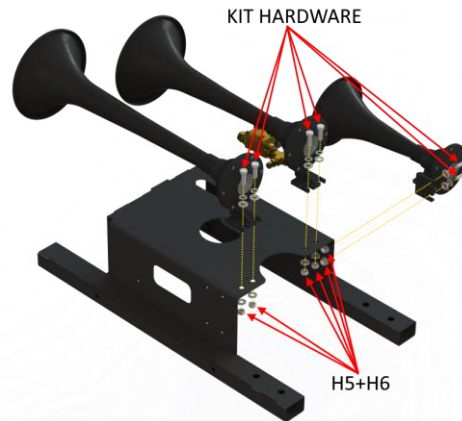

Figure 9: Horn Installation (734 horns, default config. shown)

8.4.2 Assemble Compressor to USTL Structure

1. Use the hardware supplied with the compressor to attach the compressor to the USTL structure. Place the head of the compressor towards the end of the USTL structure with the plate with a diamond-shape cutout.

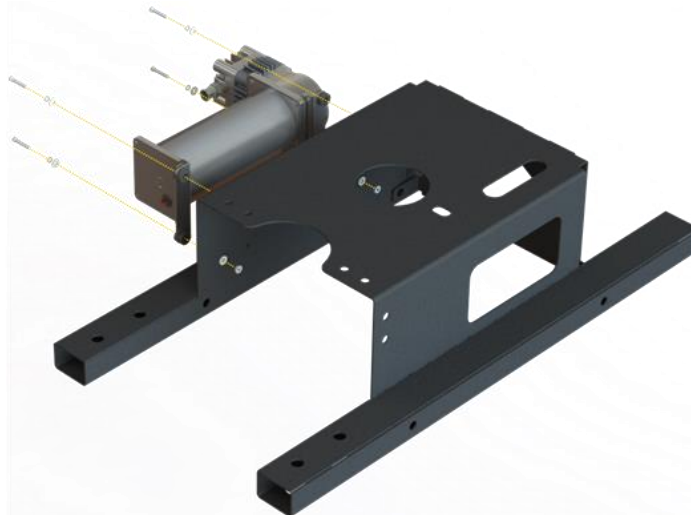

Figure 10: Compressor Installation (6450RC shown) (other components hidden for clarity)



8.4.3 Assemble Tank to USTL Structure

1. Use [H7](#), [H8](#) (2x), [H9](#), & [H10](#) to attach the tank to the USTL structure. Align ports as shown.

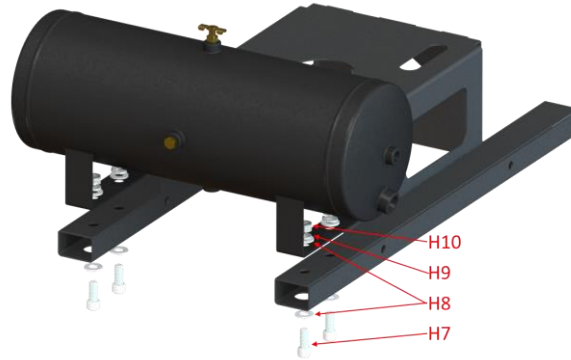

Figure 11: Tank Installation (other components hidden for clarity)

Note: If tank bolt holes do not line up, adjust inner/outer bolts on threaded rod nearest the tank to pull/push holes closer/further apart.

8.4.4 Adhere Rubber to USTL Structure

1. Remove adhesive strip backing from item [H11](#)(2x). Attach the rubber strips along the full length of the bottom side of the USTL structure as shown.

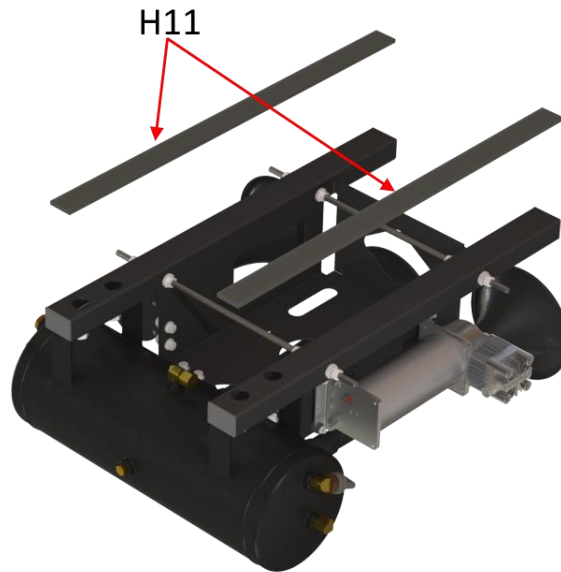

Figure 12: Rubber Stripping Installation



8.4.5 Install Snap-In Caps

1. Insert item [H12](#) (4x) in each end of the USTL structure tubes.

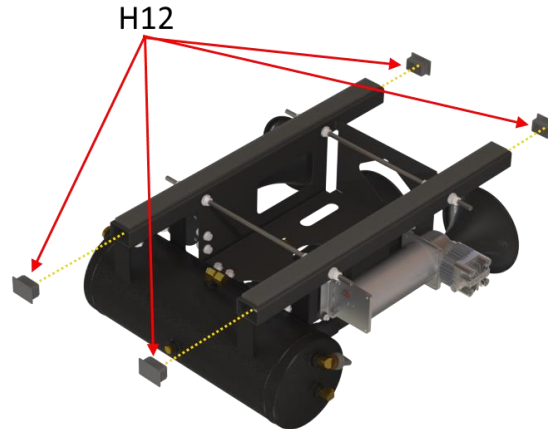

Figure 13: Snap-In Cap Installation

8.4.6 Attach Leader Hose to Tank & Route Air to Horns

1. Attach the compressor's leader hose to the tank inlet.
2. Run an airline from the tank outlet to the horn solenoid.
3. Use [H14](#) on edges of the bracket where the airline passes through, in order to protect the airline from abrasion.

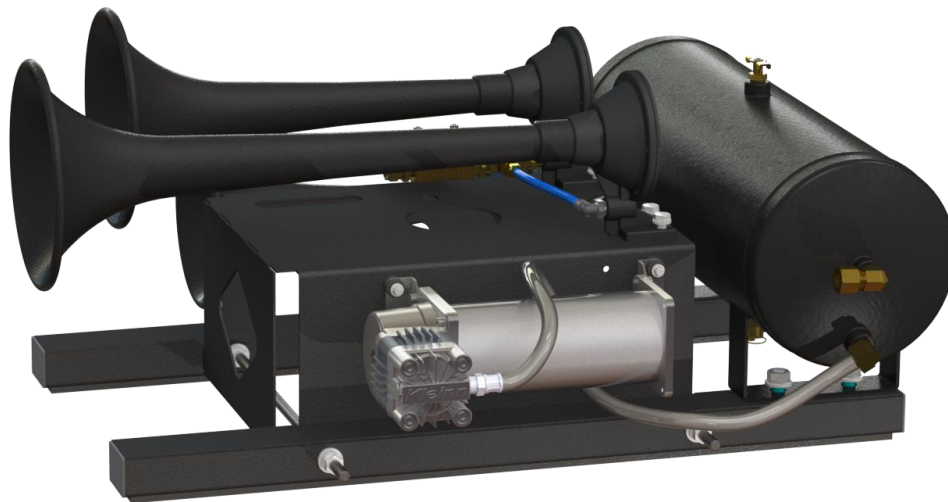

Figure 14: USTL Bench Assembly

END OF SECTION

Kleinn Air Horns



USTL-230/734
INSTALLATION MANUAL



9 On-Vehicle Mechanical Assembly

Complete the following steps on-vehicle.

9.1 Remove Spare Tire

1. Consult your owner's manual to lower and remove the spare tire.
If the spare tire is not present, lower the winch.

The assembly will be raised in to place after electrical connections have been made. See [Section 11](#)

END OF SECTION



10 On-Vehicle Electrical Installation

CAUTION: Follow all recommended safety precautions for working on vehicle's electrical system; consult vehicle owner's manual for further instruction.

10.1 Relay & Fuse Diagram for Air Horn System

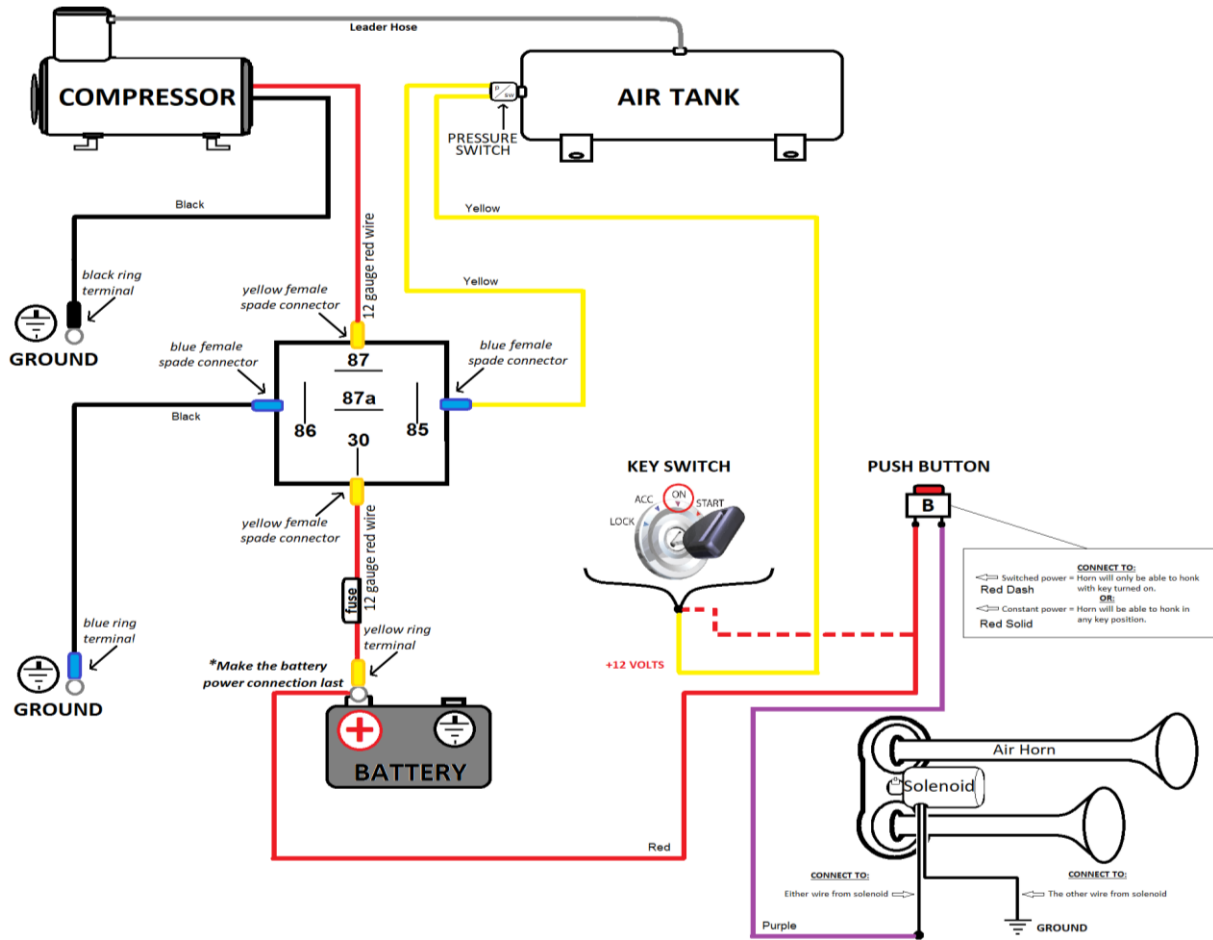

Figure 15: Suggested Ignition Relay Diagram for Air Horn System

<p>PRESSURE SWITCH (either wire can go to Relay or Ignition)</p>			<p>AIR HORN SOLENOID (either wire can be PWR or GND)</p>
--	--	--	--



10.2 Disconnect Vehicle Battery(s)

1. Consult owner's manual to disconnect your vehicle's battery.

10.3 Connect Wires to Fuse & Relay

1. Find a suitable location for supplied fuse and relay. Shown below is an example location under the hood, next to the battery, mounted on the firewall. Use supplied self-tapping screws, as necessary.

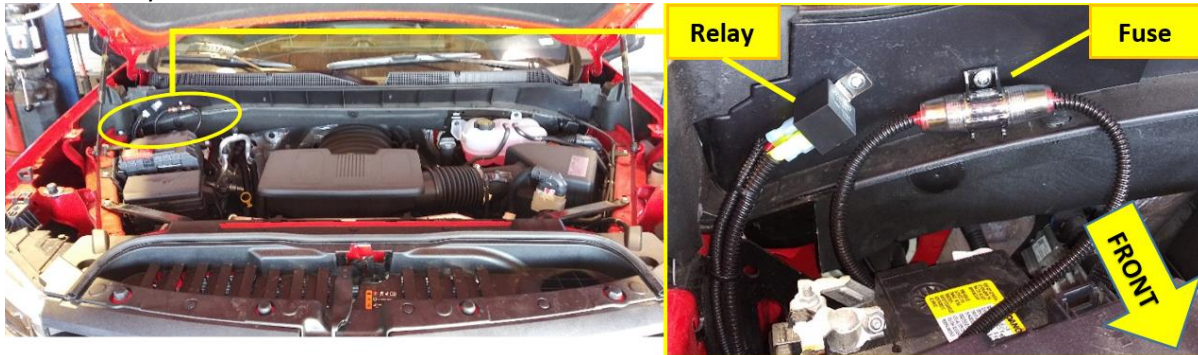

(example image)

2. Install the supplied fuse holder on one end of power wire by cutting the loop in fuse holder and connecting supplied Ring terminal to one end and butt connector on the other end.
3. **CAUTION:** Do not install 30-amp fuse until all electrical connections are final.



10.4 Install Horn Button

1. Find a suitable location for the horn button (i.e., in dash, center console, etc.). Verify location has at least 1" of clearance behind for terminal connectors. Mark location for drilling.
2. Drill a 3/4" hole in this location. Route the horn button wires to the hole, then slide push-button retaining nut over wires and connect wiring. Install the button into the hole and tighten the retaining nut from the backside.



Figure 16: Horn Button Installed in Dash



Figure 17: OE Upfitter Switches

NOTE: FOR VEHICLES WITH OE/FACTORY UPFITTER SWITCHES:

If your vehicle is equipped with factory upfitter (i.e., auxiliary) switches, you may elect to use one of them for your Kleinn Air Horn kit. Consult your owner's manual, or dealership, for further instructions on what wire terminals/fuse block location to use and what programming may be required.

10.5 Connect Pressure Switch

1. Route wiring, as desired, to the air tank and connect to the pressure switch, per wiring diagram.
NOTE: Either pressure switch wire can be connected to relay or ignition; they are identical.

10.6 Connect Air Compressor

1. Route wiring, as desired, to the air compressor and connect, per wiring diagram.

10.7 Connect Air Horn Solenoid(s)

1. Route wiring, as desired, to the air horns and connect to the solenoid(s), per wiring diagram.
NOTE: Either air solenoid wire can be connected to power (PWR) or ground (GND); they are identical.

10.8 Raise USTL Assembly into Final Position

1. Insert the spare tire winch flange through the 3-1/4" hole on the USTL.
2. Using the spare tire winch, raise the USTL structure into its final position.

Guide the USTL up, into place, as it is being raised.

Ensure the rubber on the USTL tubes is contacting the frame crossmembers (red arrows below, cross-members will vary by model).

Some models may require the USTL to be installed in a different configuration or orientation.

(See [application chart](#))

NOTE: Ensure the USTL is fully secured by winch tension.



Figure 18: USTL Assembly Installation

10.9 Secure Wiring to Vehicle

1. Insert all wiring into included wire loom and ensure loom is away from all sharp edges, hot/moving vehicle parts, (i.e., exhaust, engine, radiator) and fasten securely to vehicle using supplied zip ties or equivalent.

END OF SECTION

11 Final Steps & Testing

11.1 Reconnect Vehicle Battery(s)

CAUTION: Before connecting the vehicle battery(s), verify all wiring is properly connected and no shorts exists. Use of Multi-meter, or test light is recommended to check continuity of all connections.

11.2 Test Air Compressor

1. Turn the vehicle ignition to the *ON* position and allow the compressor to fill the air tank. Initial fill may take approximately 1.5-3 minutes. The air compressor should shut off automatically once full pressure is achieved.
2. If the compressor runs excessively, (i.e., 5 minutes or more) disconnect electrical power to the air compressor and listen for air leaks in system. Repair any problems and retest. Contact Kleinn technical support if problems persist.
3. Inspect all air line connections (i.e., air tank fittings, quick connect fittings, air horn fittings, etc.) for leaks by using a soap and water solution sprayed directly onto fittings.
4. System must be pressurized, or at least the air compressor must be running.
5. If an air leak is found:
6. Safely release air pressure from system (i.e., slowly open drain valve).
7. Disassemble leaky connection, re-seal and reinstall fittings as needed.

11.3 Test Train Horns

1. Allow the air compressor to run and shut-off automatically (i.e., air tank is full)
2. Verify all tubing and electrical wires are securely fastened to the vehicle, brackets, or kit parts. If necessary, use extra zip ties to hold tubing and wire in place.
3. Ensure all nearby persons have adequate hearing protection and provide courtesy warning to neighbors or others in vicinity.

WARNING: NEVER operate train horns with ears close to trumpets or in an enclosed space without [substantial hearing protection](#) (i.e., > Ear Plugs and Earmuffs) for all persons closer than 100 feet from vehicle. Never

operate train horns outdoors when persons are near vehicle without adequate hearing protection.

4. Briefly activate the horns by pressing the horn button for one (1) second. Repeat three (3) times with a short rest period between (i.e., 1-3 seconds).
5. Horns should sound as expected and be loud. [click to listen to example 230 Kit](#)
6. Horn sound/loudness will taper quickly as the air tank pressure decreases.
7. Allow the air compressor to refill the tank, if needed, and activate the horns for three (3) second period to ensure the horns are functioning properly.

11.4 Test Quick Connect Coupler

1. Allow the air compressor to refill the tank, if needed.
2. Attach the supplied INF-1 inflator kit to the quick connect coupler and verify adequate air pressure is available
3. Test fill tires on vehicle, bicycle, etc.
4. Test air blow gun
5. Test air impact gun

END OF SECTION



12 General Operation

12.1 Compressor Operation

WARNING: NEVER operate the air compressor above its MAXIMUM PRESSURE RATING (see label on body). Operation exceeding maximum pressure will damage the compressor and potentially cause air system failure.

1. Kleinn's oil-less compressor is equipped with an automatic thermal overload protection circuit designed to protect the air compressor from overheating and causing permanent damage.
2. Automatic thermal overload protector will reset after 30 minutes.
3. To prevent discharge of the vehicle's battery, and for best performance, keep the vehicle's engine running while using the air compressor for any prolonged use (i.e., filling tires, using air tools, etc.).

12.2 Horn Operation

1. Allow the air compressor to run until it shuts off automatically, (i.e., air tank is full) or for at least one minute between horn activations.
2. Press the horn button to activate the horns
3. Horn sound/loudness will taper quickly as the air tank pressure decreases.
4. Horns should sound for 3-7 seconds depending on kit and tank size.

WARNING: NEVER operate train horns with ears near trumpets or in an enclosed space without [hearing protection](#) (i.e., > Ear Plugs/Muffs) for all persons closer than 100 feet from vehicle. Never operate train horns outdoors when persons are near vehicle without hearing protection.

END OF SECTION

13 Routine Maintenance

Perform following maintenance at least once during recommended intervals:

1. Yearly, or every 12,000 miles, verify all mounting fasteners are properly torqued. Applying witness

marks across fasteners and mounting parts is good practice to quickly ensure fasteners have not moved.

2. Yearly, or every 12,000 miles, **inspect OE wiring, tubing, cables, etc.** where kit parts may touch to **verify no abrasion or rubbing.**
3. Yearly, or every 12,000 miles, remove all road grime and mud from the mounting brackets and kit parts using clean water from a garden hose. Pay special attention to corners where dirt may collect. Touch up all paint chips using automotive grade enamel in either spray or brush form.

NOTE: Do this more frequently if traveling regularly off-road, or in winter climates with road salts. High-pressure washers may damage part finishes and must be used with care.

4. Yearly, or every 12,000 miles, check electrical connections, wires, and air fittings for abrasion, corrosion, or other damage. Replace damaged components.

NOTE: if system runs continuously or turns on unexpectedly, leaks or a poor electrical connection may be present.

5. Monthly, or every 10 hours of compressor run time, drain moisture from the air tank using the drain valve installed at the bottom of the tank.

WARNING: Failure to regularly drain the air tank may result in corrosion inside the tank and possible failure in the tank or air tubing, causing injury.

6. Yearly, or every 12,000 miles, clean or replace the air compressor air filter element. Replacement frequency depends on operating frequency and conditions of environment (i.e., daily use requires more frequent changes). Order replacement filters at Kleinn.com.

NOTE: NEVER lubricate or add liquids to the compressor.

END OF SECTION



14 Warranty Information

Thank you for purchasing USTL-230/734. Shall you experience any unexpected problems during installation, or have problems with any part at any time, please contact Kleinn support.

KLEINN MANUFACTURER LIMITED DEFECT WARRANTY:

Kleinn Automotive Air Horns warrants this product to the end-user, when properly installed and under normal conditions of use, to be free from defects in workmanship and materials for a period of one year from the provided date of purchase, to the original purchaser of the product. This warranty does not cover abuse, operation in a manner inconsistent with the product's design, or damage resulting from exposure to the elements. If the defect is considered "under warranty", Kleinn will, at its option, repair or replace the product free of charge to the original purchaser. Kleinn is not liable for any installation charges, loss or damage of any kind incurred in the replacement or repair of any warranted product.

END OF MANUAL

© Kleinn Air Horns 2020, All rights reserved.

PO Box 91278 Tucson, AZ 85752

Phone: (520) 579-1531

Web: <https://www.kleinn.com>